

WATERMAN

# TYPE "C"

CONSTANT UPSTREAM LEVEL GATE

- Automatic
- No Operator, No Motor
- Simple, Accurate, Fast and Reliable
- For Flood Control
- For Water Management Systems
- For Irrigation
- For Wastewater Treatment

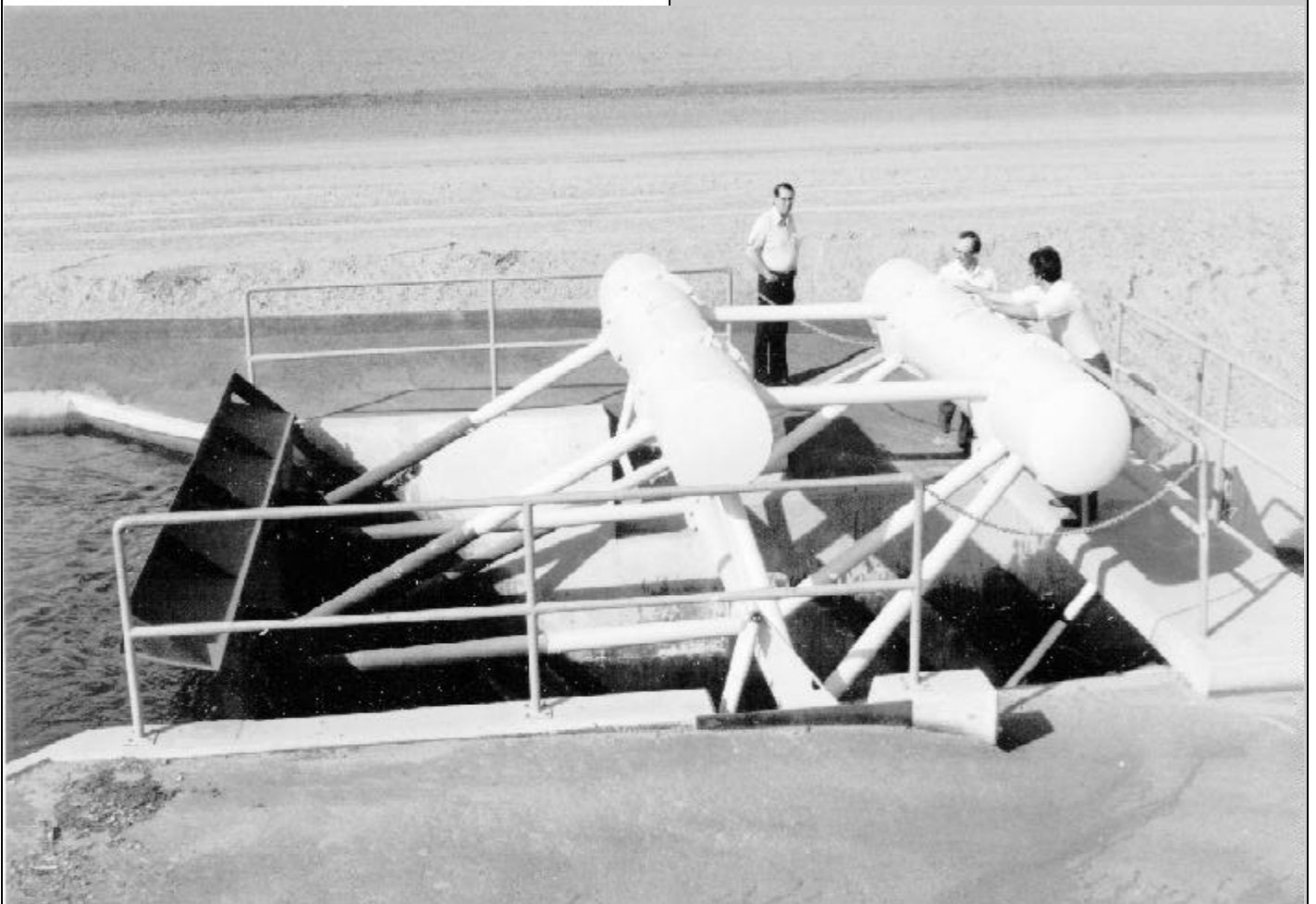

WATERMAN

# TYPE "C"

## CONSTANT UPSTREAM LEVEL GATE

The Waterman Type "C" gate automatically maintains a *constant* water level on the *upstream* side of the gate section. It operates ...

- without any outside power or motor
- free of any manual intervention
- irrespective of the volume of incoming flow
- independently of the downstream level

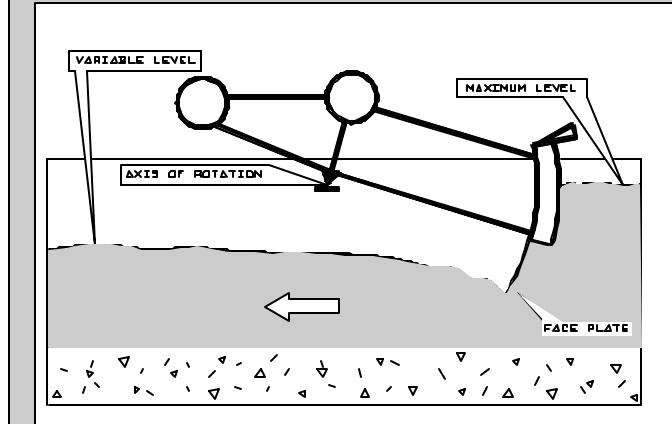

### FEATURES:

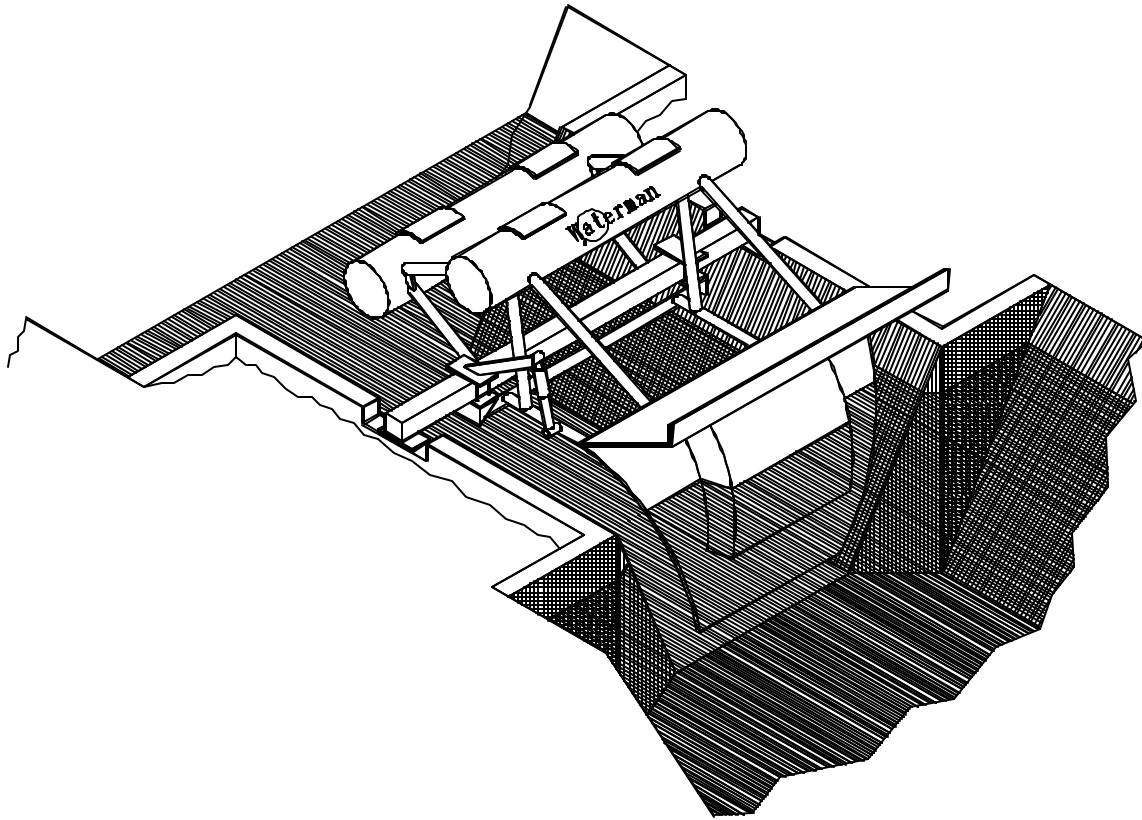

maintains a pleasantly constant water level in all seasons.

**On flood control or water supply reservoirs,** the Type "C" gate permits a large increase in storage volume without sacrificing spillway capacity of reliability.

**On wastewater treatment plants,** the Type "C" gate acts to provide a constant level to the clarifier effluent trough, preventing odor stipping.

**On irrigation canals,** the Type "C" gate maintains a

high and constant head on turnouts, irrespective of flow in the canal or through the turnouts. Used in series along the distribution network, at different check structures, Type "C" gates insure an automatic, safe, reliable, and flexible irrigation program, at sharply reduced labor costs.

**Waterman** INDUSTRIES, INC.

## OPERATING PRINCIPLE

The Waterman Type "C" gate maintains the upstream water level constant for any given discharge.

The torques generated by the hydraulic thrust on the face plate and the weight of the gate are equal and opposite for all angular positions of the Waterman Type "C" gate only when the upstream water level is at the elevation of the gate trunnion axis.

As long as this condition is fulfilled, the gate will remain motionless, in complete equilibrium.

Whenever the flow varies and the upstream water level has a tendency to rise or fall, the gate adjusts its opening immediately, automatically passing the exact discharge required to keep the upstream water level constant.

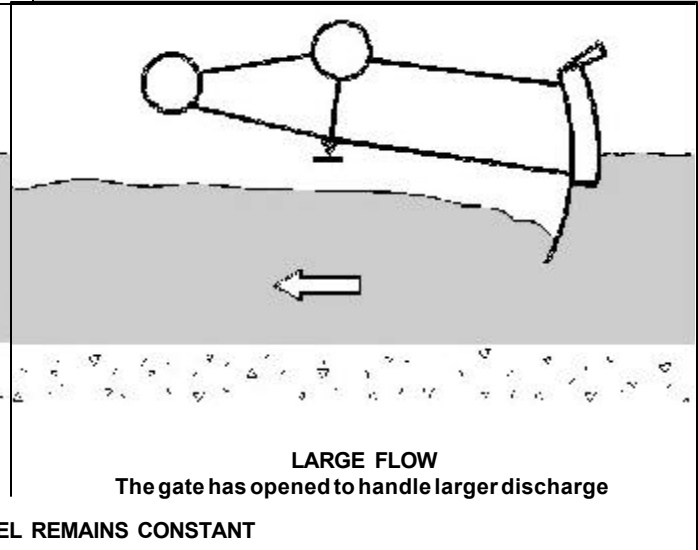
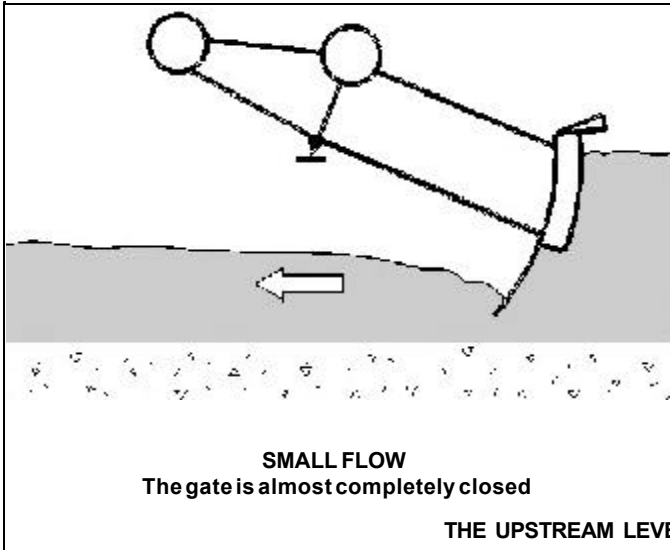

THE UPSTREAM LEVEL REMAINS CONSTANT

## TYPE "C" GATES DESIGNED FOR MAXIMUM PROFITS

### Savings on Operational Cost

Once installed, a Waterman Type "C" gate requires no further adjustment; there is no need for any manual intervention. Ever! There is also no need for expensive power supplies.

### Savings on Canal and Structure Investment

A smaller freeboard is permissible, without the risk of overtopping; so:

- for new canals, design capacities can be met by smaller cross-sections, therefore lower construction costs
- for old canals, capacities through existing cross-sections can be increased
- for both old and new canals, higher heads are made available at turnouts

### Savings on Emergency Canal Repairs

Damage due to overtopping of banks is eliminated, because check structures equipped with Type "C" gates are always ready to operate instantly as needed, and are not subject to human or power failure.

Other unscheduled expenses are avoided because banks are no longer subject to dangerous underpressures caused by water level fluctuations.

Also, wet lining is no longer periodically exposed to the sun.

### Savings on Maintenance

The Waterman Type "C" gate has only one sturdy moving part of strong, heavy-gauge steel plate; frame and bearings remain above water. It has been designed for easy access to all surfaces requiring paint.

Bottom flow past the gate reduces sediment deposits; side flow prevents the accumulation of trash at the check structure.

### Savings of Water in Distribution Networks

Canal operation becomes much simpler because manual intervention is unnecessary at Type "C" check structures. Thus a more accurate and far more flexible distribution system is available, reducing costly water waste.

**QUIET**  
**FAST**  
**AUTOMATIC**  
**EXPENSE-FREE OPERATION**

**EFFICIENT**  
**RELIABLE**  
**ACCURATE**

... a system that knows how to adjust instantly to changing flows at any time.

In addition, Waterman Type "C" gates have been designed to complement the esthetic appearance of water management projects. They give a feeling of balance and their pleasant silhouette blends well with canal landscaping.





The Waterman Type C-21 gate, the largest in the series, is more than 26 ft. wide at the top. It is capable of regulating flows from almost zero to 2,000 cfs. Whatever the flow, the upstream level (seen here) will remain constant.



BEFORE

Ditch riders, who day and night had to manipulate flash boards at the old check structure, are no longer needed at the replacement structure equipped with the two Waterman C-16 gates, handling up to 950 cfs.  
- Gridley, California



AFTER

Erection in the field is very simple and requires no welding. Step-by-step instructions permit gate installation to be completed in one or two days. Waterman Type "C" gates are fully assembled in the shop and checked out, then dismantled for shipment and easy installation.

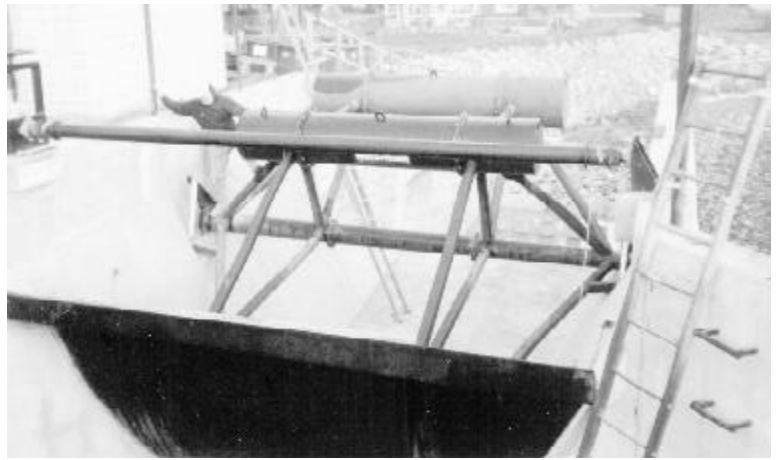

Waterman C-15 controls the water level in Tulare Lake Basin Water Storage District lateral canal, facilitating water deliveries to a large area of California's most productive farmland.



This gate has opened to permit a larger volume of water to pass, always keeping upstream water level constant. This C-12 gate can handle 145 cfs. Irrigation canals equipped with Waterman Type "C" gates, such as this one, can be filled to maximum capacity without fear of overtopping.



Three Waterman C-21 gates in parallel operation in a flood control and drainage network. Each gate handles 2,000 cfs.  
-Sugarland, Texas



## SELECTING YOUR WATERMAN TYPE "C" GATE

Type "C" gates are manufactured in 21 standard sizes, designated C-1 through C-21.

Plot on the chart below the point corresponding to:

1. Maximum discharge  $Q_m$  to be handled at the gate.
2. Minimum head differential  $J_m$  available at maximum discharge for the equipped structure.

Find the proper gate size on the first black line to the right of this.

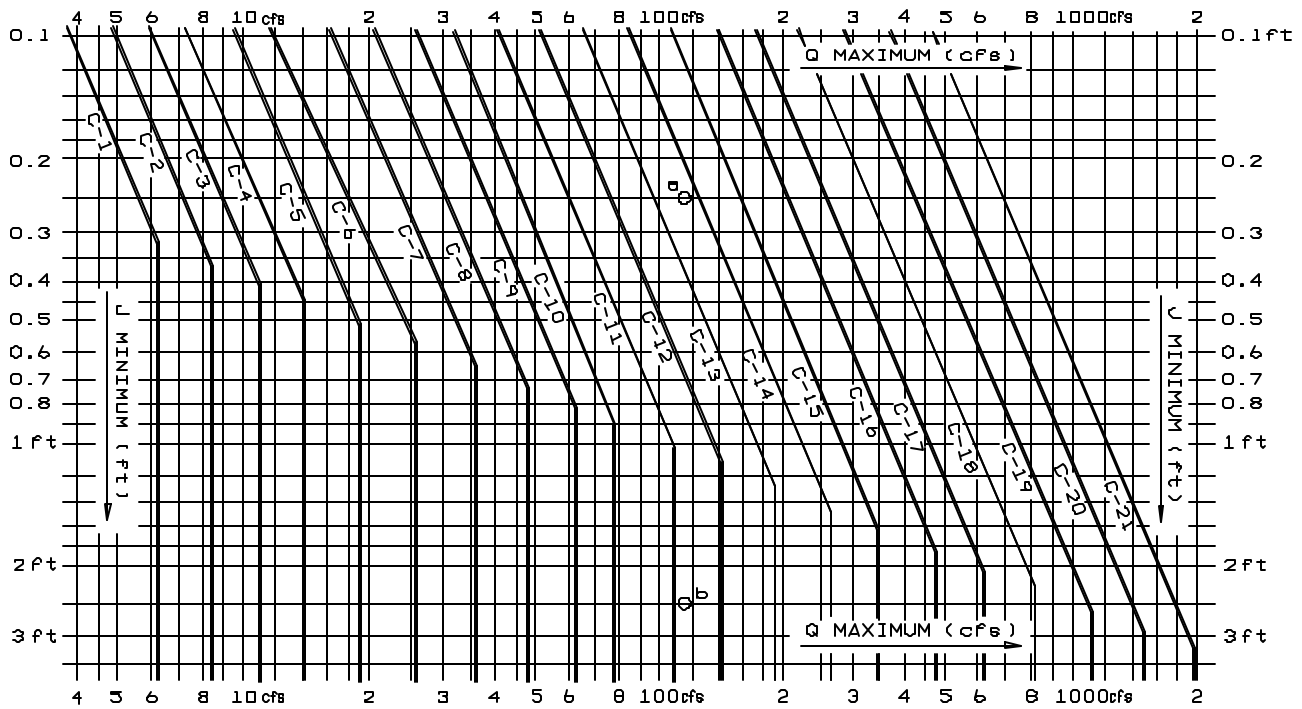
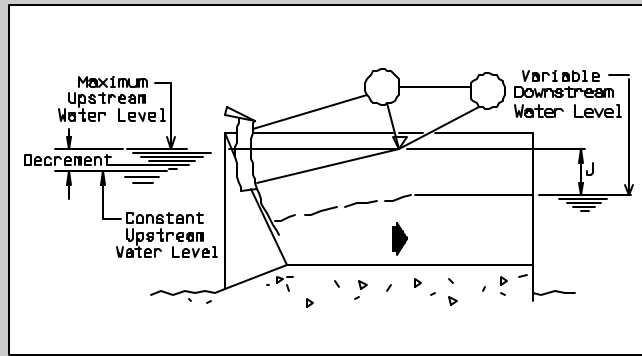

**GATE SIZE SELECTION CHART**  
Hydraulic Data based on TRANOR Standard Structure (see next page)

### Example 1:

The water level must be kept constant at elevation 54 ft. in a canal, at a location where the maximum discharge is 115 cfs. Maximum tailwater elevation is 53.75 ft. Which gate is suitable?

The *minimum head differential* available for the equipped structure is  $J_m = 54.00 - 53.75 = 0.25$  ft. Point *a* on the chart corresponds to  $Q_m = 115$  cfs and  $J_m = 0.25$  ft. The suitable gate size is the C-14.

Note that for a head differential of 0.25 ft., the C-14 capacity is 124 cfs.

### Example 2:

The free surface elevation of a lake has to be maintained constant. The maximum discharge at the outlet is equal to 115 cfs and the drop is 2.50 ft. Which gate is suitable?

Point *b* on the chart corresponds to the above data and the suitable gate size is now the C-12.

Note that the C-12 has a maximum capacity of 142 cfs.

**Two or more Waterman Type "C" gates can be installed side by side (in parallel) to increase capacity, to reduce head differential or to better match structure and site.**

## HOW TO DESIGN THE STRUCTURE

The TRANOR Standard Layout is recommended for the installation of Waterman Type "C" gates. It leads to excellent hydraulic performance at minimum construction cost.

Other structure designs may be used (for instance, to suit local site requirements) leading, perhaps, to slightly different hydraulic characteristics. In this case a layout should be submitted to WATERMAN INDUSTRIES, INC., for further advice.

All dimensions are related to the gate trunnion axis O. Remember that the elevation of this axis is also the nominal value of the maximum upstream W.L. to be controlled by the gate. Note that this W.L. can be adjusted, within the limits, after gate installation (to correct a small error in gate setting, or to control a different W.L., etc.)

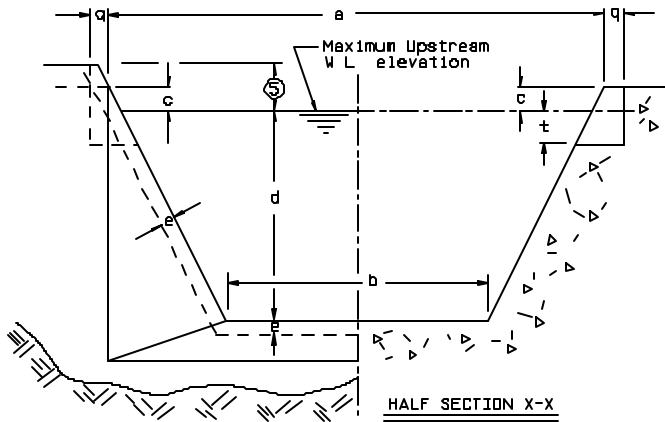

Blockout areas (1), (2) and (3) are provided in first stage concrete for grouting in gate components. Grout to be smoothed out flush with wall surface.

H and V are horizontal and vertical components of gate thrust on each (one) bank.

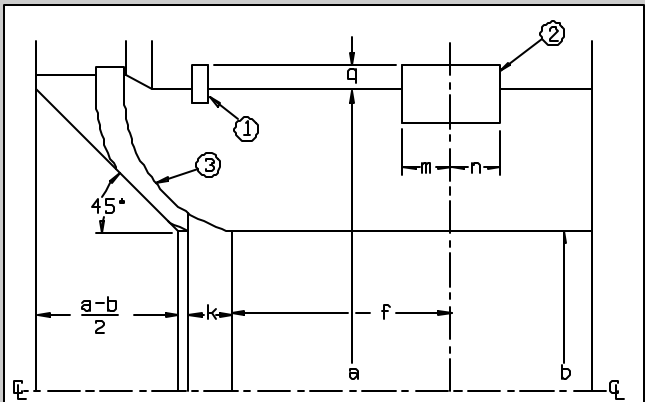

1/2 PLAN VIEW

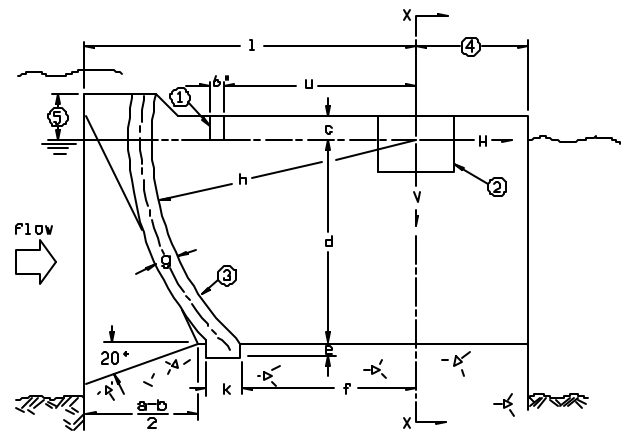

- (1) On left bank only, for C-17 and larger.
- (4) Determined by structure stability and concrete strength requirements.
- (5) Freeboard according to local conditions.

Larger structure drawing, with additional details, available upon request.

TYPE C	a ft. - in.	b ft. - in.	c in.	d ft. - in.	e in.	f ft. - in.	g in.	h ft. - in.	k in.	l ft. - in.	m in.	n in.	q min. in.	t in.	u ft. - in.	H lbs.	V lbs.	D Index No.
C-1	2 - 9½	1 - 5¾	1½	1 - 2¼				2 - ¾		2 - 6	6	6	6	6	-	40	100	80
C-2	3 - 1½	1 - 7¾	2	1 - 3¾	N/A	N/A	N/A	2 - ¾	N/A	2 - 6	6	6	6	6	-	56	110	90
C-3	3 - 5¾	1 - 10	2	1 - 5¾				2 - ¾		2 - 6	6	6	6	6	-	80	130	100
C-4	3 - 10½	2 - ¾	2¼	1 - 7¾				2 - ¾		2 - 6	6	6	6	6	-	112	150	110
C-5	4 - 4	2 - 4	2¾	1 - 10				2 - 11½		3 - 7	7	7	8	8	-	160	250	125
C-6	4 - 11	2 - 7½	3¼	2 - ¾	N/A	N/A	N/A	2 - 11½	N/A	3 - 7	7	7	8	8	-	224	310	140
C-7	5 - 7	2 - 11½	3½	2 - 4				2 - 11½		3 - 7	7	7	8	8	-	315	400	160
C-8	6 - 2¾	3 - 3¼	4	2 - 7½	4	2 - 10	6	4 - 1¼	8	5 - 0	9	9	8	8	-	450	625	180
C-9	6 - 11½	3 - 8	4	2 - 11½	4	2 - 6	6	4 - 1¼	9	5 - 0	9	9	8	8	-	630	750	200
C-10	7 - 9	4 - 1¼	4½	3 - 3½	4	2 - 0	6	4 - 1¼	10	5 - 0	9	9	8	8	-	900	850	220
C-11	8 - 8¼	4 - 7	5¼	3 - 8	6	3 - 5	6	5 - 3	12	6 - 4	10	10	10	8	-	1,250	1,400	250
C-12	9 - 10	5 - 3	5¾	4 - 1¼	6	2 - 10	6	5 - 3	13	6 - 4	10	10	10	8	-	1,800	1,700	280
C-13	11	5 - 10¾	7¾	4 - 7	6	4 - 2	8	6 - 6¾	13	7 - 11	10	10	12	10	-	2,500	2,500	315
C-14	12 - 3¾	6 - 6¾	7¾	5 - 3	6	3 - 4	8	6 - 6¾	13	7 - 11	10	10	12	10	-	3,550	3,000	355
C-15	13 - 11¼	7 - 4¼	8	5 - 11	6	5 - 3	8	8 - 2½	13	9 - 10	12	12	14	10	-	5,000	5,000	400
C-16	15 - 7	8 - 2½	9½	6 - 6¾	6	4 - 4	8	8 - 2½	16	9 - 10	12	12	14	10	-	7,100	6,000	450
C-17	17 - 4¾	9 - 2¼	10¾	7 - 4¼	6	6 - 8	10	10 - 4	15	12 - 5	22	12	8	24	7 - 0	10,000	9,100	500
C-18	19 - 8¾	10 - 4	11¾	8 - 2½	6	5 - 7	10	10 - 4	17	12 - 5	22	12	8	24	7 - 0	14,000	12,000	560
C-19	21 - 11¼	11 - 7¾	13¾	9 - 2¼	6	8 - 10	10	13 - 1½	16	15 - 9	24	16	12	30	9 - 0	20,000	18,000	630
C-20	24 - 7¼	13 - 1½	15¾	10 - 4	6	7 - 5	10	13 - 1½	17	15 - 9	24	16	12	30	9 - 0	28,000	22,000	710
C-21	27 - 10¾	14 - 9¼	17¾	11 - 7¾	6	8 - 4	10	14 - 9¼	17	17 - 9	28	20	16	36	10 - 0	40,000	36,000	800

N/A = NOT APPLICABLE



**TYPICAL SPECIFICATIONS FOR  
WATERMAN TYPE "C" AUTOMATIC LEVEL CONTROL GATE**

**1. APPLICABLE PUBLICATIONS.** The Steel Structures Painting Council (SSPC) Publications listed below form a part of this specification to the extent referenced. The publications are referred to in the text by the basic designation only

SSPC SP 10	(1985) Near White Blast Cleaning
SSPC PS 11.01	(1982) Black (or Dark Red) Coal Tar Epoxy Painting System

**2. SUBMITTALS.**

**2.1 Shop Drawings.** Shop drawings shall be submitted in accordance with the SPECIAL CLAUSES. Submittals shall include a complete list of equipment and materials, including manufacturer's descriptive and technical literature, performance charts and curves, catalog cuts, and installation instructions. Drawings shall show proposed layout and anchorage of the system and appurtenances, design of structure to receive gates and equipment relationship to other parts of the work including clearances for maintenance and operation. Manufacturer's descriptive data and installation instructions shall be submitted for approval.

**2.2 Certificate of Compliance.** A certificate of compliance that the gates furnished are in conformance with the drawings and specifications shall be submitted to the project engineer.

**2.3 Operating Instructions.** The manufacturer shall furnish the engineer with six (6) complete copies of operating characteristics and instructions outlining the step-by-step procedure required for system start-up and system operation. The instructions shall include the manufacturer's name, model number, service manual, parts list, and brief description of all equipment and their basic operating features.

**2.4 Maintenance Instructions.** The manufacturer shall furnish the engineer with six (6) copies of maintenance instructions listing routine maintenance procedures, possible breakdown and repairs, and troubleshooting guide.

**2.5 Spare Parts Data.** After approval of the shop drawings, the contractor shall furnish spare parts data for each different item of materials and equipment furnished. Data shall include a complete list of spare parts and supplies, with current unit prices and source of supply.

**3. MANUFACTURER'S SERVICES.** The Contractor shall obtain the services of a factory field representative experienced in the calibration and balancing of the equipment specified. The representative shall supervise the calibration and balancing of the equipment for proper operation.

**4. SHIPMENT AND DELIVERY.** Gates shall be shipped from factory in components or subassemblies to be bolted together in the field to the exclusion of any field welding. The dimensions of individual components shall be compatible with rail or road transportation clearances. Match marks shall be provided on the heaviest components to facilitate field erection. When shipping and delivering gate components, the gates shall be handled carefully to ensure a sound, undamaged condition. Particular care shall be taken not to damage any coating.

**5. MATERIALS.**

**5.1 General.** The automatic level control gate shall be constant upstream level, Type "C", and be completely self operating with an integrated float-ballast design. The gates shall be manufactured by Waterman Industries, Inc., 209/562-4000, or an approved equal in quality, characteristics and performance.

**5.2 Standard Products.** Materials and equipment shall be the standard product of a manufacturer regularly engaged in the manufacture of this type of product and shall essentially duplicate items that have been in satisfactory service for more than five (5) years prior to bid opening. Substitute manufacturer may submit



alternate design which has been tested and certified by an independent laboratory. All materials used in construction of the gate shall be new and selected according to the best engineering practice for this type of equipment. Equipment shall be supported by a service organization that is, in the opinion of the engineer, reasonably convenient to the site.

**5.3 Steel.** Steel shall be ASTM A-36.

**6. OPERATION REQUIREMENTS.** The gate shall operate automatically, regulating the upstream water level with no external power, motor or level sensors and hoists, and no manual intervention, under the following conditions:

(insert your particulars here, such as elevations, head differential and flows)

**6.1** Within the above specified limits, the upstream level shall be controlled irrespective of the downstream level conditions, gate opening and discharge rates.

**7. GATE CONSTRUCTION.**

**7.1** The gates shall be fabricated from materials as per paragraph 5, Materials, and designed to withstand the pressure forces produced by the upstream water level at its maximum elevation, with no tailwater (and, as the case may be, by the exceptional maximum tailwater level).

**7.2** The gates shall mainly consist of a radial shaped faceplate, suitably reinforced and matching trapezoidal-shaped sluice way, a framework including the float and ballasting compartments, and two bearings to be anchored in the concrete structure.

**7.3** The gates shall include an adjustable counterweight, suitable for accurate, sensitive and stable gate operation. The gate shall be carefully checked and adjusted to tolerances required in the factory for straight forward field erection and proper operation.

**8.0 SURFACE PREPARATION AND PAINTING.** Surface preparation shall consist of near white blast cleaning (SSPC SP 10) of all surfaces. Mechanical surfaces shall be protected by appropriate masking. Protective coating shall consist of

- a. On machined surfaces, one coat of gasoline-soluble, rust-preventing compound.
- b. On all other surfaces, including surfaces to be grouted in, two coats of factory applied coal tar epoxy paint (SSPC PS 11.01) for corrosion protection from water and corrosive environment.
- c. Coating touch-up kit.

(Alternate surface preparations and coatings may be specified.)

**TYPE "C" CONSTANT UPSTREAM LEVEL GATE  
SUMMARY OF IMPORTANT FACTS**

**I. Standard Sizes and Performance**

Type "C" Gates are fabricated in 21 standard sizes:

Type C-1 (up to 6.5 cfs) to Type C-21 (up to 2,000 cfs).

The Type "C" Gate maintains the upstream level constant independently of discharge fluctuations or downstream level variations. The gate reaction to incoming discharge changes is immediate and there is no variation of the upstream water level.

**II. HEAD AND MAXIMUM DISCHARGE**

For a given gate size, there is no upper limit to the head J (difference in elevation between upstream and downstream levels). When J is increased, the gate capacity increases up to a maximum value, then remains constant, irrespective of any further increase in head J; in other words, gate capacity is no longer affected by further decreases in the downstream level.

For example:           The Type C-21 will handle up to:  
                                  Q = 1,200 cfs with J = 1 ft.  
                                  It will handle up to a maximum  
                                  Q<sub>M</sub> = 2,000 cfs with J 3.4 ft.

If J increases beyond 3.4 ft., the normal gate capacity does not increase any longer. Should the incoming flow to the gate exceed 2,000 cfs, the gate will pass this discharge but will no longer maintain the upstream level at its constant elevation.

**III. WHAT HAPPENS IF...?**

... the incoming discharge exceeds the gate capacity?

The gate will handle this extra discharge, but will not control the upstream level at a constant elevation any longer. The maximum upstream water level, not to be exceeded in order to avoid overtopping of the gate, is .009D ft. above the gate axis or rotation (d: index number of the gate). Provided that tailwater elevation remains sufficiently low to insure a free flow at the gate section, the discharge through the structure will increase by approximately one-third of the maximum capacity for the gate size (for this maximum upstream elevation).

For example:  
The Type C-21 will handle any flow up to 2,000 cfs while controlling the upstream water level at a constant elevation, say elevation 100.0.

The upstream level can rise up to elevation 107 ft (without overtopping gate) and the installation will then pass a discharge equal to approximately 2,700 cfs, provided that tailwater elevation is sufficiently low to insure a free flow at the gate section.

**IV. DEPTH OF WATER**

The depth of water directly at the face plate is given on page 9 of the Waterman Type "C" Gate Brochure. This is dimension "d" and it represents only a local water depth, vertical distance between the controlled water level and the structure sill.

Further upstream, the water depth may be different, as depth in the approach channel, reservoir, etc., does not affect the operation of the gate.

For example:  
A channel which is 6 ft. deep, has a flow which varies from a few cfs to a maximum of 800 cfs and a Type C-18 has been selected for the control of the upstream level.

Page 9 of the Waterman Type "C" Gate Brochure shows that for the Type C-18, d = 8' 2 1/2".

A local excavation will allow construction of the structure at the proposed location and the channel invert will be slightly modified in the vicinity of the structure, sloping down from the original invert elevation to the structure sill.

As an alternate, three smaller Type C-14 could also be installed in parallel and handle the required flows. In this case d = 5'3" and the bottom of the gate sluice will be slightly higher than the canal invert.

In other words:  
Depth of the approach channel, reservoir, etc. is immaterial for selection of the gates. Gate size is determined solely by the maximum flow to be handled and the minimum head differential available:

- if the depth of water is shallower than dimension "d", the structure receiving the gate requires some excavation.
- on the contrary, if the depth of water is greater than "d", the sill of the structure is set higher than the invert of the channel.

**V. VOLUME OF CONCRETE FOR STANDARD STRUCTURE**

The volume of concrete required for a typical structure built in accordance with the recommended Tranor Standard Layout can be computed, for estimating purposes, by the formula:



$$v \text{ (cu. yd.)} = 0.37 \left( \frac{D}{100} \right)^3 \quad \text{Select "D" from chart on page 9}$$

for example: For a Type C-18 (maximum capacity 800 cfs):

$$v = 0.37 \left( \frac{560}{100} \right)^3 = 65 \text{ cu. yd.} \quad \text{(wing walls and/or stilling basin, should they be needed, is additional.)}$$

This volume is sufficient to insure the stability of a structure built on an earth foundation (crest of an earth dam, earth canal, etc.), and for the only purpose of accommodating the gate. Of course, exact volume of concrete depends on site conditions.

The above formula is not applicable for a gate to be installed in a concrete dam, where addition of a sluice may, in fact, lead to a reduction in the total volume of concrete.

## VI. ADDITIONAL BENEFITS

When incorporating our equipment within a system, one must take into account the extent of savings generated by the following facts:

- a. Savings in salaries, ditchriders or operators are not necessary.
- b. Savings in energy cost and repairs of the control mechanisms, motors, relays, etc., which are part of conventional "automated" equipment. Our sturdy and reliable equipment is practically maintenance-free, which means:
  - no time wasted for undue and complicated repairs
  - no unpredictable but "built-in" incidents, as the water itself actuates our most complicated equipment
  - no hit-or-miss type of operation
- c. Waterlines are perfectly defined and controlled in a system equipped with our equipment, thus, channels can be accurately designed for their maximum capacity, freeboard reduced to a minimum and safety margins for operating errors can be eliminated.
- d. No operating costs and no maintenance costs (except for occasional inspection and repainting of the gates) have to be accounted for when Waterman Type "C" Gates have been installed in a system.

## VII. PREFABRICATED CONTROL STRUCTURES

Prefabricated Control Structures are available, and are particularly attractive for smaller installations (with Type "C" Gates up to size C-10, approximately).

They are composed of a Prefab Metal Sluice, designed in accordance with the TRANOR Standard Layout, and a Type "C" Gate.

### The drawings that follow show typical applications.

#### 1) Installation on earth canal

The Prefab Metal Sluice, set at the proper elevation, is secured with earth and rip rap back filling. A seepage plate, extended laterally by bolted wing walls provides additional anchoring of the structure.

#### 2) Installation in concrete rectangular channel

The Prefab Metal Sluice is provided with bolted brackets to be grouted in blockout areas on lateral concrete walls and a vertical plate matching the shape of the channel cross section. Rubber seals can be fitted on lateral and bottom edges to prevent leakages around the plate.

The advantages of Prefabricated Control Structures are numerous and, depending on local conditions, some may be decisive:

- No need for designing and building a concrete structure. Waterman Industries will supply a complete package for a control structure which can be easily and quickly installed by, for instance, a maintenance crew.
  - The Prefab Control Structure can be rest at minimal cost if a different constant water level elevation is selected. On an irrigation canal, the control structure can also be removed from one site to another if new turnout locations should be decided upon.
  - The Prefab Metal Sluice can be used as a form to be embedded if lining of an earth canal is later decided, providing a substantial saving on the check structure's construction.
  - On concrete rectangular channels, a Prefabricated Control Structure can be installed without dewatering. Larger Prefab Control Structures can be furnished upon request for applications precluding dewatering for installation.
- 3) A patented, adjustable prefab sluice way is an option which will allow the end user to adjust the "set" level of the Waterman Type "C" level control gate.

**WATERMAN TYPE "C" GATE OVERALL DIMENSIONS AND CLEARANCES**



**WATERMAN TYPE C AUTOMATIC LEVEL CONTROL GATE MOUNTED IN A WATERMAN PREFABRICATED CONTROL STRUCTURE**

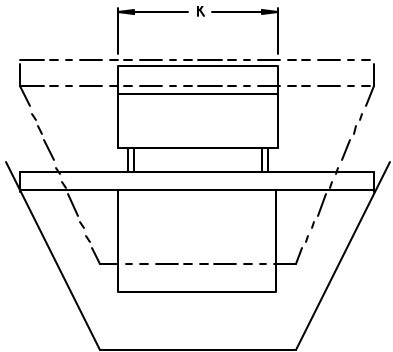
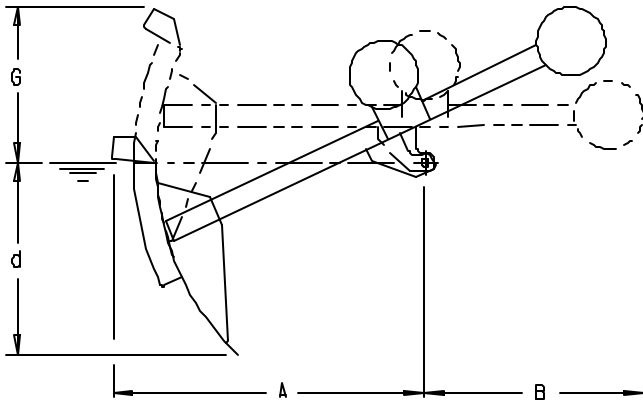

MODEL	A Ft. - In.	B Ft. - In.	G Ft. - In.	K Ft. - In.	d Ft. - In.	W Ft. - In.	V Ft. - In.
C-1	2 - 6	1 - 8	1 - 2	1 - 10	1 - 2 ¼	2 - 10	1 - 4 ½
C-2	2 - 6	1 - 8	1 - 3	1 - 10	1 - 3 ¾	3 - 2	1 - 6
C-3	2 - 6	1 - 8	1 - 4	1 - 10	1 - 5 ¾	3 - 6	1 - 8 ½
C-4	2 - 6	1 - 8	1 - 6	1 - 10	1 - 7 ¾	3 - 11	1 - 10 ½
C-5	3 - 6	2 - 5	1 - 8	2 - 6	1 - 10	4 - 4	2 - 1 ½
C-6	3 - 6	2 - 5	1 - 10	2 - 6	2 - ¾	4 - 11	2 - 4 ½
C-7	3 - 6	2 - 5	2 - 1	2 - 6	2 - 4	5 - 7	2 - 8
C-8	4 - 9	3 - 5	2 - 2	3 - 4	2 - 7 ½	6 - 3	3 - 0
C-9	4 - 9	3 - 5	2 - 6	3 - 4	2 - 11 ½	7 - 0	3 - 5
C-10	4 - 9	3 - 5	2 - 10	3 - 4	3 - 3 ½	7 - 9	3 - 9 ½
C-11	6 - 2	4 - 0	2 - 11	5 - 4	3 - 8	8 - 8 ¾	4 - 5
C-12	6 - 2	4 - 0	3 - 5	5 - 4	4 - 1 ¼	9 - 10 ½	4 - 11 ¼
C-13	7 - 9	4 - 10	3 - 9	6 - 8	4 - 7	11 - 0	5 - 6 ½
C-14	7 - 9	4 - 10	4 - 5	6 - 8	5 - 3	12 - 3 ¾	6 - 3 ¾
C-15	9 - 8	6 - 2	4 - 9	8 - 3	5 - 11	13 - 11 ¼	7 - 1 ¾
C-16	9 - 8	6 - 2	5 - 6	8 - 3	6 - 6 ¾	15 - 7	7 - 7 ½
C-17	12 - 2	7 - 9	6 - 0	14 - 0	7 - 4 ¼	17 - 4 ¾	8 - 10
C-18	12 - 2	7 - 9	7 - 0	14 - 0	8 - 2 ½	19 - 8 ¼	9 - 11
C-19	15 - 6	9 - 8	7 - 5	18 - 0	9 - 2 ½	21 - 11 ¼	11 - ¾
C-20	15 - 6	9 - 8	8 - 8	18 - 0	10 - 4	24 - 7 ¼	12 - 5 ¼
C-21	17 - 3	11 - 6	9 - 3	21 - 0	11 - 7 ¾	27 - 10 ¾	14 - 2 ½



**PREFABRICATED CONTROL STRUCTURE  
TYPICAL INSTALLATION ON EARTH CANAL**

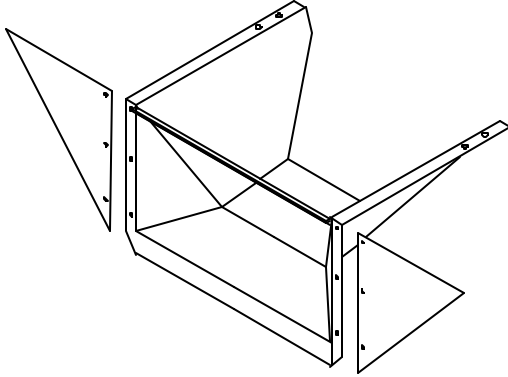

PREFAB METAL SLUICE WAY

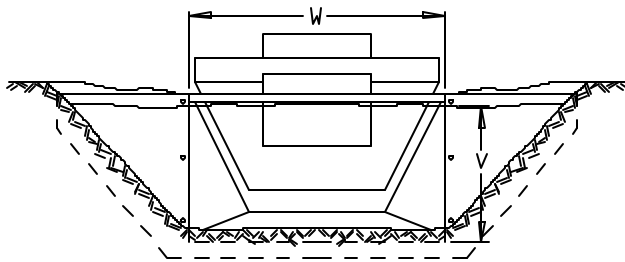

UPSTREAM VIEW

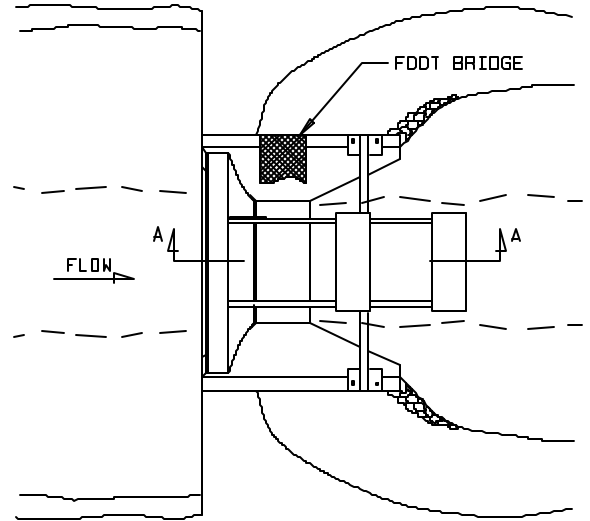

PLAN VIEW

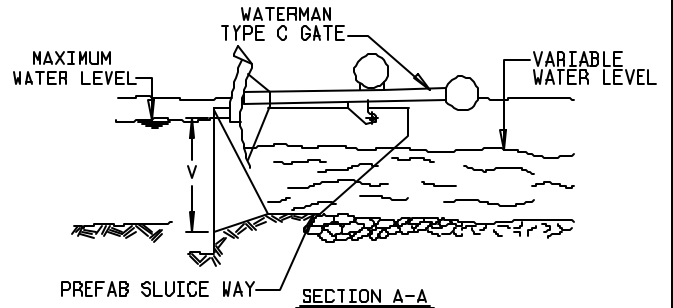

SECTION A-A

**PREFABRICATED CONTROL STRUCTURE  
TYPICAL INSTALLATION ON CONCRETE CHANNEL**

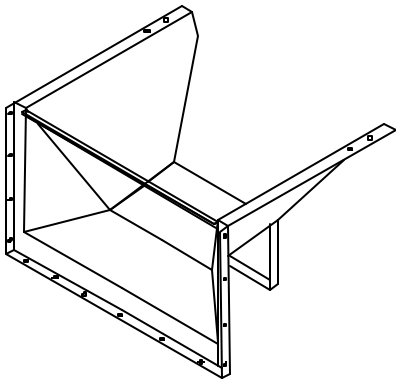

PREFAB METAL SLUICE WAY

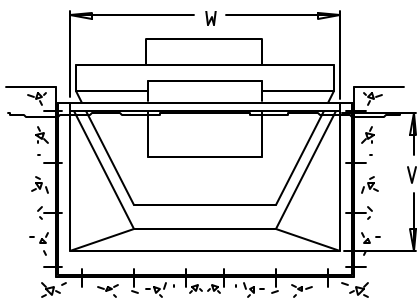

UPSTREAM VIEW

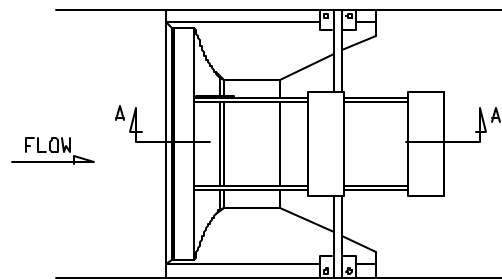

PLAN VIEW

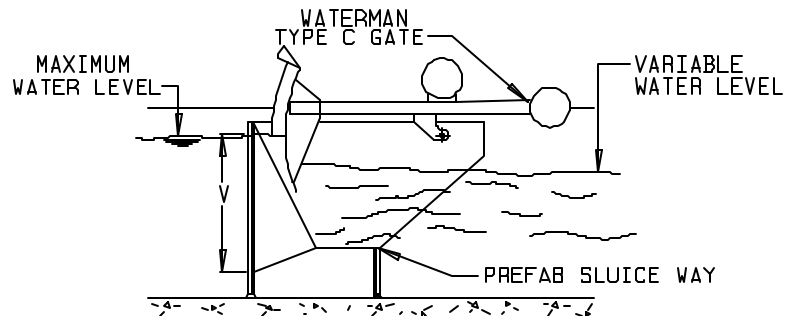

SECTION A-A

**VARIABLE UPSTREAM LEVEL CONTROL WITH ADJUSTABLE SLIDING WEIR SLUICeway UNIT**

Automatic level control gate installations that can control variable fixed upstream water levels can now be accommodated with an integral ADJUSTABLE SLIDING WEIR SLUICeway gate module developed and patented by Waterman Industries.

The new unit provides the opportunity to select an upstream water level simply by adjusting the elevation of the module itself. Water passage remains restricted solely to the usual response of the automatic level control action. "J" shaped seals provide watertight integrity for the sliding element.

The Waterman ADJUSTALBE SLIDING WEIR SLUICEWAY units offer this new versatility to provide control of user-selected upstream water levels while retaining the unique automatic qualities of operation without any outside power or motor, without operating personnel, and irrespective of the volume of incoming flow and independent of the downstream level.

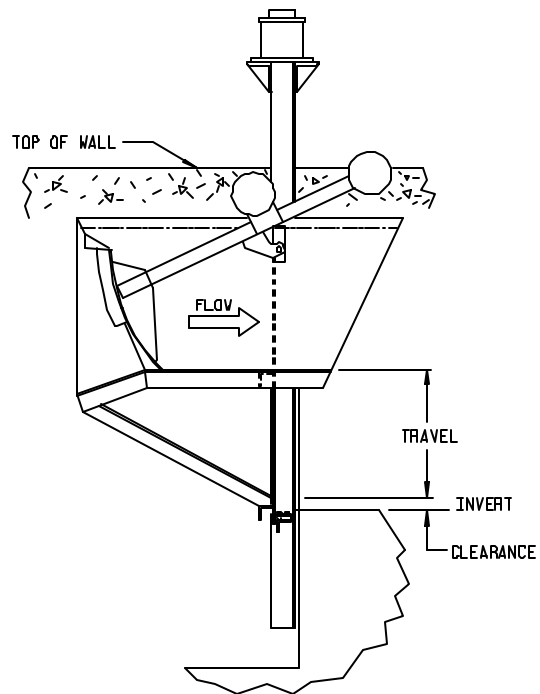
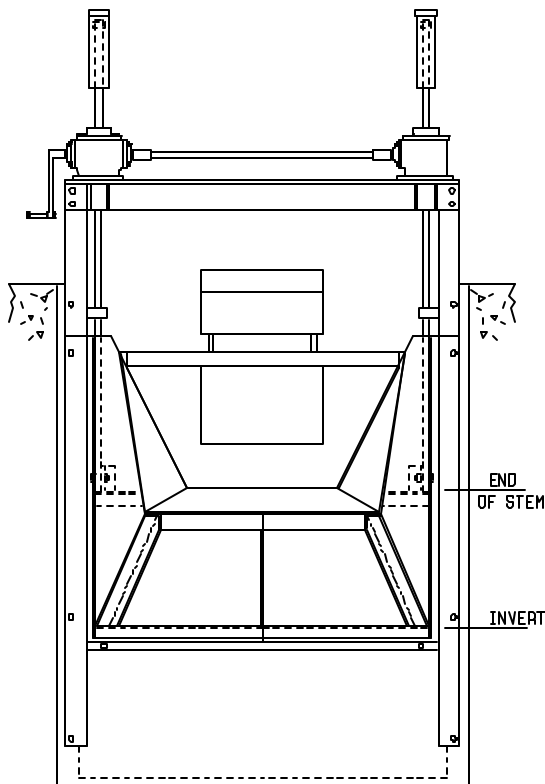
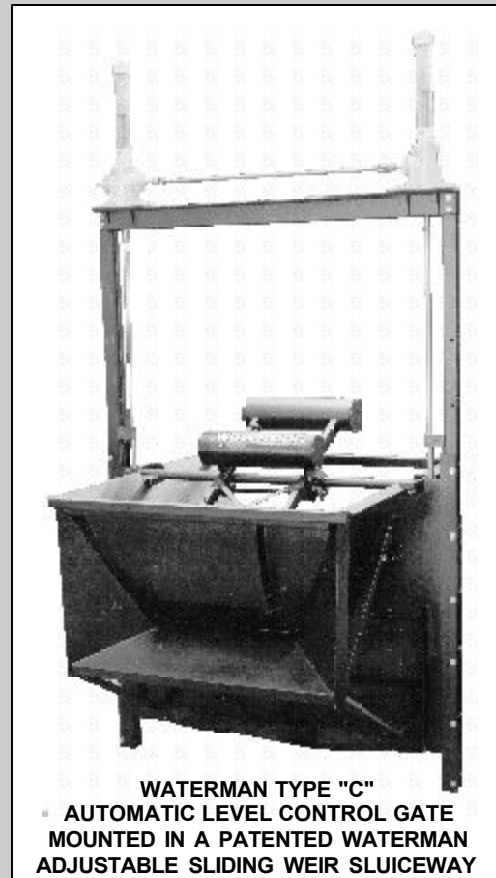

## SAMPLE WATERMAN TYPE "C" GATE INSTALLATION FOR SMALL HYDROELECTRIC APPLICATIONS

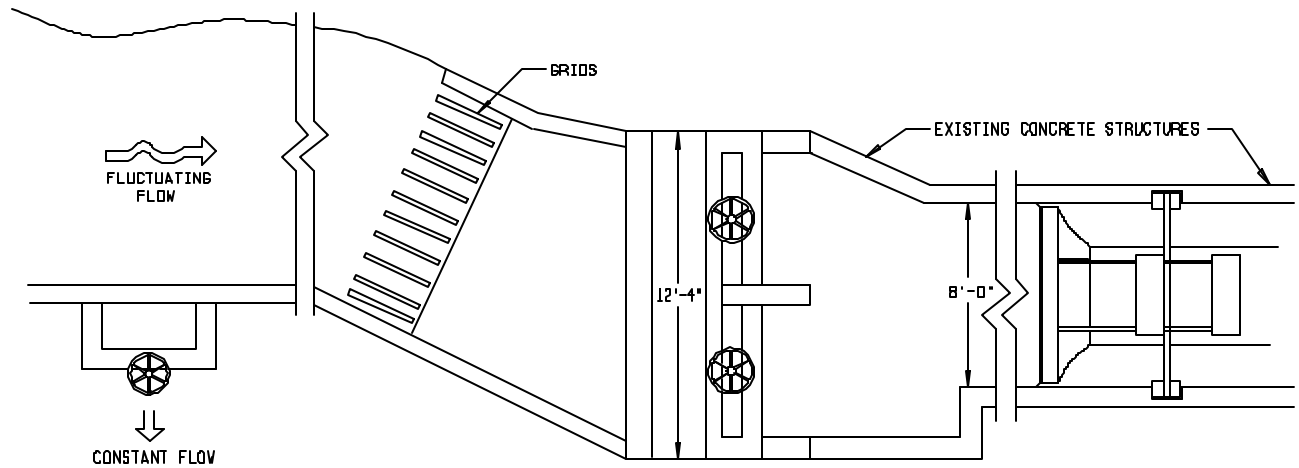

PLAN VIEW

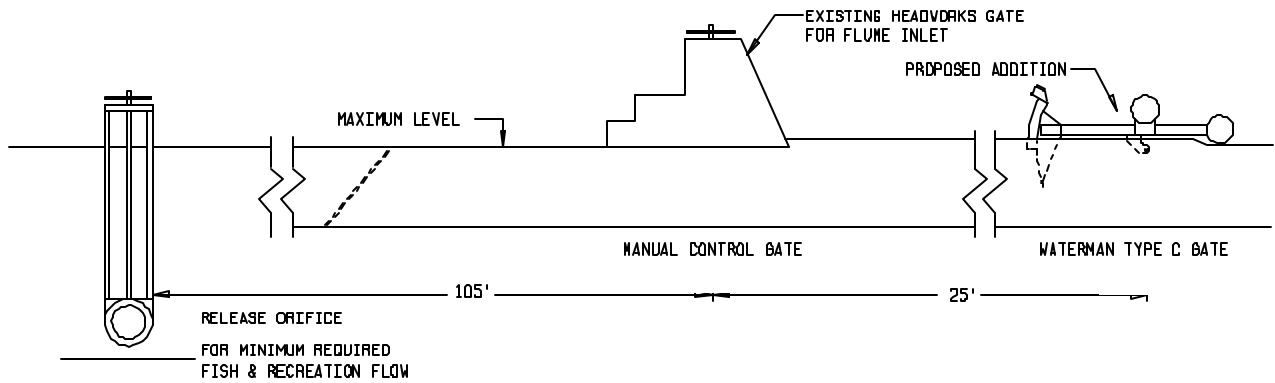

SECTION VIEW

### TYPICAL SMALL HYDROELECTRIC APPLICATION

The Waterman Type "C" gate with prefabricated sluiceway is placed directly into an existing channel and provides a maximum upstream level of water for the release gate.

With maximum head, the release gate can be adjusted one time and will always provide the required fish and recreation flow downstream of the diversion dam regardless of fluctuations in river flow.

By automating the headworks in this manner, 100% of the flow fluctuations over the minimum required release are passed on to the forebay enhancing the generating capacity of the hydroelectric plant.

## AUTOMATIC CANAL CHECK STRUCTURE



View from upstream.



View from downstream.

Type C-16 gates in parallel controlling the upstream level while passing approximately 375 cfs with only 0.25 ft. of head loss. Government Highline Canal, Grand Junction, Colorado.



Waterman Type C Automatic Level control gates maintain a constant level over a wide flow range. This enables their use in accurately controlling effluent through ultra-violet disinfecting troughs. This method of level control requires no fall at the outlet of the trough to function properly, unlike balancing type flap gates.

### ODOR CONTROL

Waterman Model C-8 in use at Annacis Island Wastewater Treatment Plant in Vancouver, B.C. The Type "C" gate acts to provide a constant level to the clarifier effluent trough, preventing odor stripping.

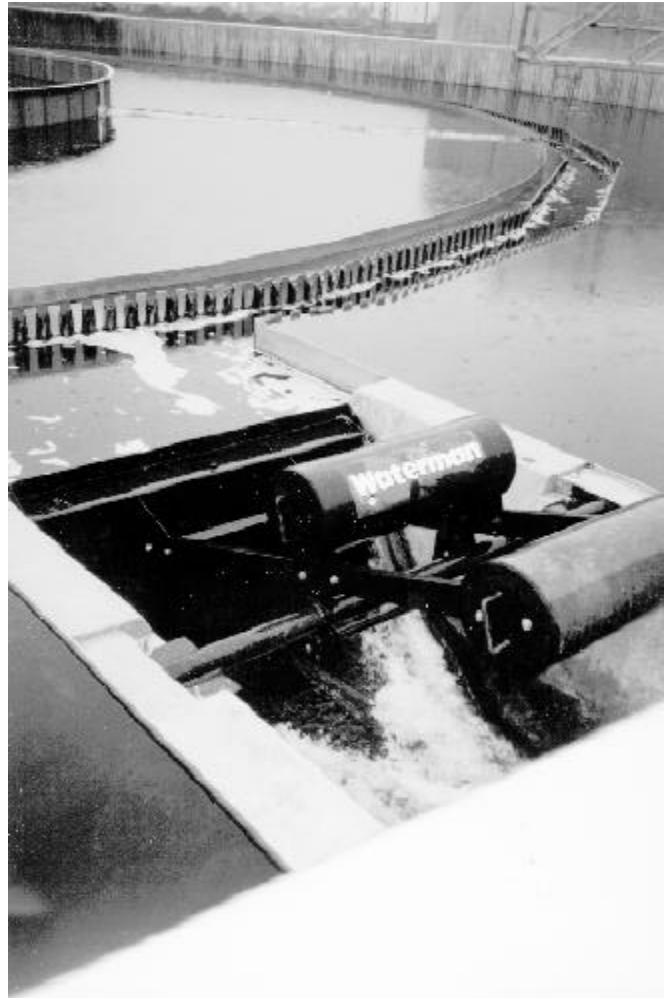



## LARGE WEIR ACROSS RIVER

Type C-17 gate controls the upstream level for all flows up to 600 cfs. Located in mid-town Wichita, Kansas.



Water flows in excess of 600 cfs are discharged over the weir.

The upstream water surface is maintained year round for park and recreation use.



## HOW, WHEN ... AND WHY?

**Q:** How accurately does the Waterman Type "C" gate maintain that constant upstream level?

**A:** A tolerance of  $\pm 0.05$  ft. is readily obtained at maximum discharge.

**Q:** How long does it take to install a Waterman Type "C" gate?

**A:** Once the concrete support structure is ready, erection of the gate and ballasting can be completed in one or two days.

**Q:** How much maintenance do Waterman Type "C" gates require?

**A:** Practically maintenance free. Bearings and damper greased once a year, and gate repainted as necessary.

**Q:** What happens if the incoming flow should accidentally exceed the gate's capacity?

**A:** The Waterman Type "C" gate will remain fully open, resting against its limit stop. The upstream water level will stabilize at an elevation higher than the normal.

**Q:** Are Waterman Type "C" gates watertight when closed?

**A:** Inasmuch as Waterman Type "C" gates have dispensed with any seals, a small leakage can be expected, but no more than 0.2 percent of maximum capacity; and this can be reduced to less than 0.1 percent, if necessary.

**Q:** Can reservoir capacity be increased by installing Waterman Type "C" gates on the spillway?

**A:** With Waterman Type "C" gates more water can be stored because water surface is safely maintained at a higher level.

## Waterman Type C Gate Applications

### Drainage Canals

- Retainage of high water surface in the drainage system automatically provides for ground water recharge and wetlands management during dry seasons.

### Recreation Lakes and Reservoirs

- Water level is maintained in all seasons without sacrificing spillway capacity or reliability.

### Flood Control

- Automatic protection of flood zones by using the Waterman Type "C" Gate as an inlet to storm water retention system.

### Irrigation Canals

- Automatic canal check gates for reliable turn-out control at all flows.

### Wastewater Treatment

- With the Waterman Type "C" Gate placed at the outlet of a clarifier the water level can be raised without sacrificing flow capacity, thereby reducing the release of odorous gases.

- Flow through the headworks can be equalized during peak and off-peak hours by using the Waterman Type "C" or Adjustable Sliding Weir Gate as an automatic bypass.

- Automatic level control for U.V. disinfection channels.

- Automatic regulation of sedimentation basin levels during fluctuating flow rates.

### Hydro-Electric

- Optimization of forebay levels while providing instant bypass during scheduled or unscheduled plant shut-downs.

- Increase hydro profitability by drawing stream diurnal flow increases into the forebay while maintaining minimum required fish and recreation flows in the stream.